

# Pricelist 03/09-A

## Tooling System

# THICK TURRET

for machines with sheet lubrication

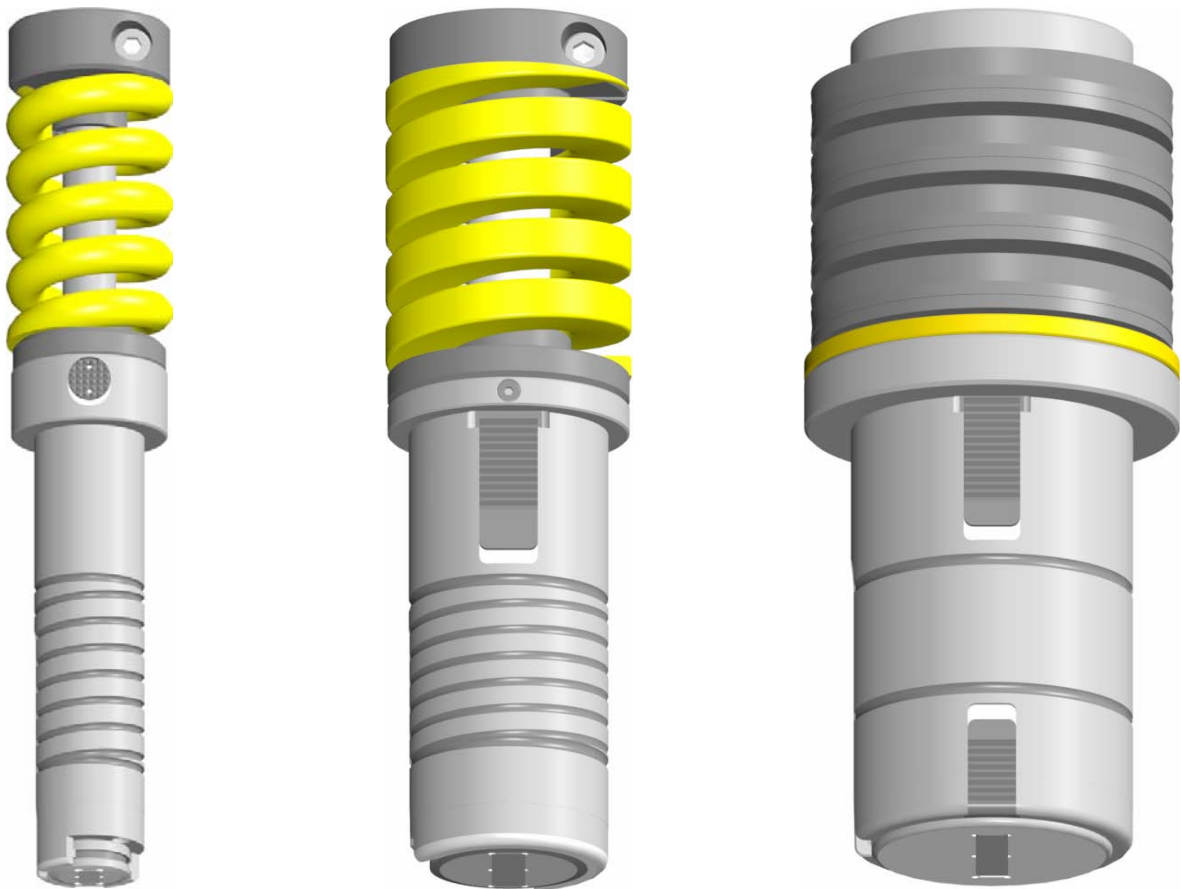



# Pricelist 03/09-A

valid from 01.08.09

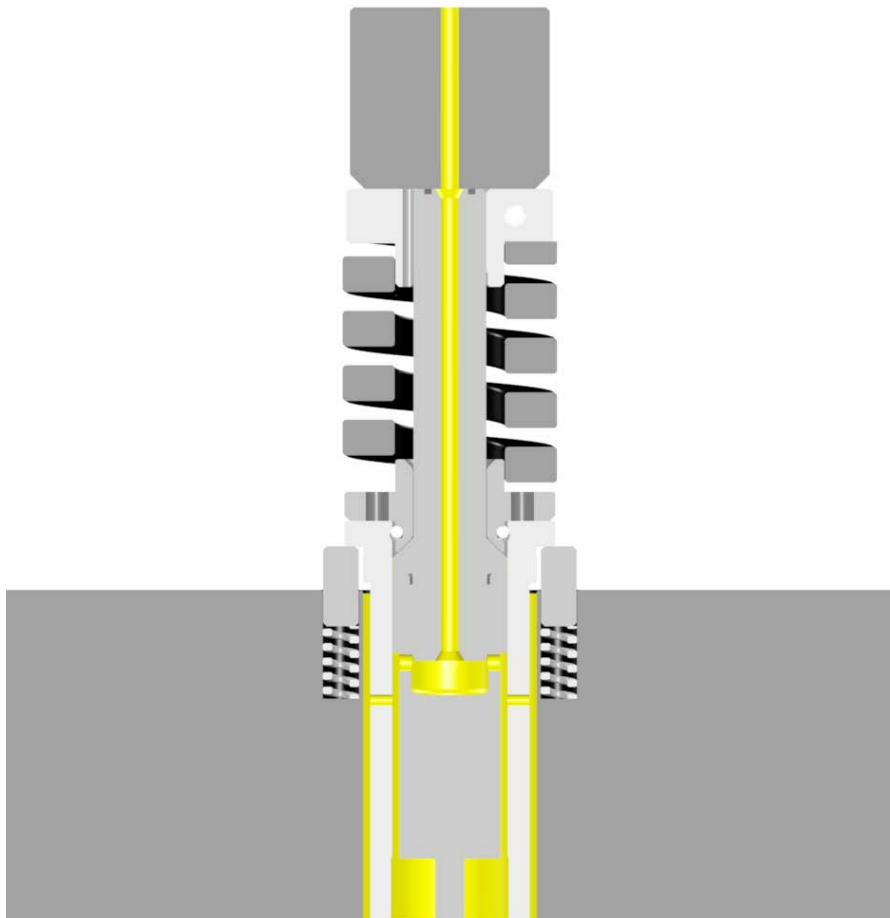

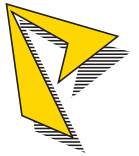

# INDEX

Station A	PASS Beta-Compact ABS	page	4 - 5
Station A	PASS Beta-V2 <sup>®</sup> ABS	page	6 - 7
Station B	PASS Beta-Compact ABS	page	8 - 9
Station B	PASS Beta-V2 <sup>®</sup> ABS	page	10 - 11
Station C	PASS Beta-V2 <sup>®</sup> ABS	page	12 - 13
Station C	PASS Beta-V2 <sup>®</sup> ABS Slitting Tool	page	14 - 15
Station D	PASS Beta-V2 <sup>®</sup> ABS	page	16 - 17
Station D	PASS Beta-V2 <sup>®</sup> ABS Slitting Tool	page	18 - 19
Station D	PASS Beta-V2 <sup>®</sup> ABS Slitting Tool close to clamp	page	20 - 21
Station E	PASS Beta-V2 <sup>®</sup> ABS	page	22 - 23
Station E	PASS Beta-V2 <sup>®</sup> ABS Slitting Tool	page	24 - 25
Station E	PASS Beta-V2 <sup>®</sup> ABS Slitting Tool close to clamp	page	26 - 27
Special shapes		page	28 - 29

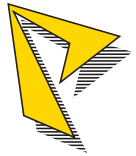

# PASS Beta-Compact ABS / Station A

Diameter up to 12,7 mm



## Head unit

Canister  
for sheet thickness up to 6 mm

Spring

10 mm length adjustment  
by thread

Oil channel for sheet lubrication



## Head unit

Canister  
for sheet thickness up to 6 mm

Spring

10 mm length adjustment  
by thread

Oil channel for sheet lubrication

Suitable for PDC-system



## Punch body

Oil channel for sheet lubrication

Alignment pin  
for exact adjustment  
(round version included)

punch body made with premium HSS  
(higher hit counts)



## Punch guide

Length adjustment by pulling down and  
turning

Surface-hardened and polished punch  
guide for sheet thickness up to 6 mm

Keyway:

Round: 0°

Square: 0-45°

rect./oblong: 0-90-225°

asym. shapes: 0-90-180-270°

Tool shape with oil channels  
integrated in guide



## Punch guide

Simple length adjustment in assembled  
state by pressing the locking button

Surface-hardened and polished punch  
guide for sheet thickness up to 6 mm

Keyway:

all shapes: 0-90°

## Stripper

Interchangeable stripper plate  
with oil channels

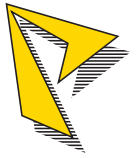

# PASS Beta-Compact ABS / Station A

Diameter up to 12,7 mm

	Part-no.	Price in €
<b>Complete Punch Assembly</b>		
Round	4018A01	
Square	4018A02	
Rectangle	4018A03	
Oblong	4018A04	
*O.D. Ground Special Shapes	4018A0G	
* EDM required Special Shapes	4018A0E	
<b>Head unit</b>		
for all shapes	4095A10	
<b>Punch body</b>		
Round	4025A01	
Square	4025A02	
Rectangle	4025A03	
Oblong	4025A04	
*O.D. Ground Special Shapes	4025A0G	
* EDM required Special Shapes	4025A0E	
<b>Punch guide</b>		
Round	4038A01	
Square	4038A02	
Rectangle	4038A03	
Oblong	4038A04	
*O.D. Ground Special Shapes	4038A0G	
* EDM required Special Shapes	4038A0E	
<b>Die</b>		
Round	4052A01	
Square	4052A02	
Rectangle	4052A03	
Oblong	4052A04	
*O.D. Ground Special Shapes	4052A0G	
* EDM required Special Shapes	4052A0E	



<b>Spare parts:</b>		
O-Ring (in punch guide)	4092A51	
PU-ejector Ø 3x6 (in punch)	4092P03	
PU-ejector Ø 6x10 (in punch)	4092P06	

<b>Additional costs for punch:</b>	
TICN coating	
T-MAX coating	
WT-shear	
DOWT-shear	
2 PT-shear	
4 PT-shear	

<b>Compensating shims for punch:</b>	
	not necessary

<b>Additional costs for punch guide:</b>	
	additional keyway

<b>Compensating shims for die:</b>	
1x0,4 mm/1x0,8 mm/1x1,2 mm	499A1M1

<b>Additional costs for die:</b>	
	reinforced die

\* see page 28-29



# PASS Beta-V2<sup>®</sup> ABS / Station A

Diameter up to 12,7 mm



## Head unit

Canister  
for sheet thickness up to 6 mm

Spring

10 mm length adjustment  
by thread

Oil channel for sheet lubrication



## Head unit

Canister  
for sheet thickness up to 6 mm

Spring

10 mm length adjustment  
by thread

Oil channel for sheet lubrication

Suitable for PDC-system



## Punch body

Oil channel for sheet lubrication

Alignment pin  
for exact adjustment  
(round version included)

punch body made with premium HSS  
(higher hit counts)



## Punch guide

Length adjustment by pulling down and  
turning

Surface-hardened and polished punch  
guide for sheet thickness up to 6 mm

Keyway:

Round: 0°

Square: 0-45°

rect./oblong: 0-90-225°

asym. shapes: 0-90-180-270°

Tool shape with oil channels  
integrated in guide



## Punch guide

Simple length adjustment in assembled  
state by pressing the locking button

Surface-hardened and polished punch  
guide for sheet thickness up to 6 mm

Keyway:

all shapes: 0-90°

## Stripper

Interchangeable stripper plate  
with oil channels

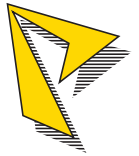

# PASS Beta-V2<sup>®</sup> ABS / Station A

Diameter up to 12,7 mm

	Part-no.	Price in €
<b>Complete Punch Assembly</b>		
Round	4019A01	
Square	4019A02	
Rectangle	4019A03	
Oblong	4019A04	
*O.D. Ground Special Shapes	4019A0G	
* EDM required Special Shapes	4019A0E	
<b>Head unit</b>		
for all shapes	4099A10	
<b>Punch body</b>		
Round	4029A01	
Square	4029A02	
Rectangle	4029A03	
Oblong	4029A04	
*O.D. Ground Special Shapes	4029A0G	
* EDM required Special Shapes	4029A0E	
<b>Punch guide</b>		
for all shapes	4039A05	
<b>Stripper</b>		
Round	4049A01	
Square	4049A02	
Rectangle	4049A03	
Oblong	4049A04	
*O.D. Ground Special Shapes	4049A0G	
* EDM required Special Shapes	4049A0E	
<b>Die</b>		
Round	4052A01	
Square	4052A02	
Rectangle	4052A03	
Oblong	4052A04	
*O.D. Ground Special Shapes	4052A0G	
* EDM required Special Shapes	4052A0E	



<b>Spare parts:</b>		
O-Ring (in punch guide)	4092A51	
PU-ejector Ø 3x6 (in punch)	4092P03	
PU-ejector Ø 6x10 (in punch)	4092P06	

<b>Additional costs for punch:</b>	
TICN coating	
T-MAX coating	
WT-shear	
DOWT-shear	
2 PT-shear	
4 PT-shear	

<b>Compensating shims for punch:</b>	
	not necessary

<b>Additional costs for punch guide:</b>	
	additional keyway

<b>Compensating shims for die:</b>	
1x0,4 mm/1x0,8 mm/1x1,2 mm	499A1M1

<b>Additional costs for die:</b>	
	reinforced die

\* see page 28-29



# PASS Beta-Compact ABS / Station B

Diameter up to 31,7 mm



## Head unit

Canister  
for sheet thickness up to 6 mm

Spring

10 mm length adjustment  
by thread

Oil channel for sheet lubrication



## Head unit

Canister  
for sheet thickness up to 6 mm

Spring

10 mm length adjustment  
by thread

Oil channel for sheet lubrication

Suitable for PDC-system



## Punch body

Oil channel for sheet lubrication

Alignment pin  
for exact adjustment  
(round version included)

punch body made with premium HSS  
(higher hit counts)



## Punch guide

Length adjustment by pulling down and  
turning

Surface-hardened and polished punch  
guide for sheet thickness up to 6 mm

Keyway:

Round: 0°

Square: 0-45°

rect./oblong: 0-90-225°

asym. shapes: 0-90-180-270°

Tool shape with oil channels integrated  
in guide



## Punch guide

Simple length adjustment in assembled  
state by pressing the locking button

Surface-hardened and polished punch  
guide for sheet thickness up to 6 mm

Keyway:

all shapes: 0-90°

## Stripper

Interchangeable stripper plate  
with oil channels

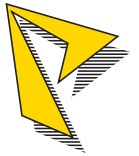

# PASS Beta-Compact ABS / Station B

Diameter up to 31,7 mm

	Part-no.	Price in €
<b>Complete Punch Assembly</b>		
Round	4018B01	
Square	4018B02	
Rectangle	4018B03	
Oblong	4018B04	
*O.D. Ground Special Shapes	4018B0G	
* EDM required Special Shapes	4018B0E	
<b>Head unit</b>		
for all shapes	4095B10	
<b>Punch body</b>		
Round	4025B01	
Square	4025B02	
Rectangle	4025B03	
Oblong	4025B04	
*O.D. Ground Special Shapes	4025B0G	
* EDM required Special Shapes	4025B0E	
<b>Punch guide</b>		
Round	4038B01	
Square	4038B02	
Rectangle	4038B03	
Oblong	4038B04	
*O.D. Ground Special Shapes	4038B0G	
* EDM required Special Shapes	4038B0E	
<b>Die</b>		
Round	4052B01	
Square	4052B02	
Rectangle	4052B03	
Oblong	4052B04	
*O.D. Ground Special Shapes	4052B0G	
* EDM required Special Shapes	4052B0E	



<b>Spare parts:</b>		
O-Ring (in punch guide)	4092B51	
PU-ejector Ø 3x6 (in punch)	4092P03	
PU-ejector Ø 6x10 (in punch)	4092P06	

<b>Additional costs for punch:</b>	
TICN coating	
T-MAX coating	
WT-shear	
DOWT-shear	
2 PT-shear	
4 PT-shear	

<b>Compensating shims for punch:</b>	
	not necessary

<b>Additional costs for punch guide:</b>	
	additional keyway

<b>Compensating shims for die:</b>	
1x0,4 mm/1x0,8 mm/1x1,2 mm	499A1M1

<b>Additional costs for die:</b>	
	reinforced die

\* see page 28-29

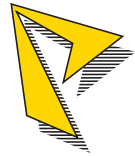

# PASS Beta-V2<sup>®</sup> ABS / Station B

Diameter up to 31,7 mm



## Head unit

Canister  
for sheet thickness up to 6 mm

Spring

10 mm length adjustment  
by thread

Oil channel for sheet lubrication



## Head unit

Canister  
for sheet thickness up to 6 mm

Spring

10 mm length adjustment  
by thread

Oil channel for sheet lubrication

Suitable for PDC-system



## Punch body

Oil channel for sheet lubrication

Alignment pin  
for exact adjustment  
(round version included)

punch body made with premium HSS  
(higher hit counts)



## Punch guide

Length adjustment by pulling down and  
turning

Surface-hardened and polished punch  
guide for sheet thickness up to 6 mm

Keyway:

Round: 0°

Square: 0-45°

rect./oblong: 0-90-225°

asym. shapes: 0-90-180-270°

Tool shape with oil channels integrated  
in guide



## Punch guide

Simple length adjustment in assembled  
state by pressing the locking button

Surface-hardened and polished punch  
guide for sheet thickness up to 6 mm

Keyway:

all shapes: 0-90°

## Stripper

Interchangeable stripper plate  
with oil channels

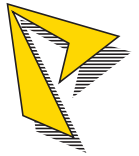

# PASS Beta-V2<sup>®</sup> ABS / Station B

Diameter up to 31,7 mm

	Part-no.	Price in €
<b>Complete Punch Assembly</b>		
Round	4019B01	
Square	4019B02	
Rectangle	4019B03	
Oblong	4019B04	
*O.D. Ground Special Shapes	4019B0G	
* EDM required Special Shapes	4019B0E	
<b>Head unit</b>		
for all shapes	4099B10	
<b>Punch body</b>		
Round	4029B01	
Square	4029B02	
Rectangle	4029B03	
Oblong	4029B04	
*O.D. Ground Special Shapes	4029B0G	
* EDM required Special Shapes	4029B0E	
<b>Punch guide</b>		
for all shapes	4039B05	
<b>Stripper</b>		
Round	4049B01	
Square	4049B02	
Rectangle	4049B03	
Oblong	4049B04	
*O.D. Ground Special Shapes	4049B0G	
* EDM required Special Shapes	4049B0E	
<b>Die</b>		
Round	4052B01	
Square	4052B02	
Rectangle	4052B03	
Oblong	4052B04	
*O.D. Ground Special Shapes	4052B0G	
* EDM required Special Shapes	4052B0E	



<b>Spare parts:</b>		
O-Ring (in punch guide)	4092B51	
PU-ejector Ø 3x6 (in punch)	4092P03	
PU-ejector Ø 6x10 (in punch)	4092P06	

<b>Additional costs for punch:</b>	
TICN coating	
T-MAX coating	
WT-shear	
DOWT-shear	
2 PT-shear	
4 PT-shear	

<b>Compensating shims for punch:</b>	
	not necessary

<b>Additional costs for punch guide:</b>	
	additional keyway

<b>Compensating shims for die:</b>	
1x0,4 mm/1x0,8 mm/1x1,2 mm	499B1M1

<b>Additional costs for die:</b>	
	reinforced die

\* see page 28-29

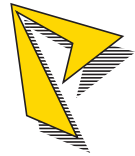

# **PASS Beta-V2<sup>®</sup> ABS / Station C**

Diameter up to 50,8 mm

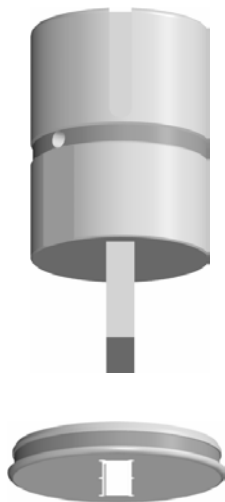

## **Guide Assembly**

Screw M12

Springs for sheet thickness up to 6 mm

Oil channel for sheet lubrication

Simple 10 mm length adjustment  
in assembled state by  
pressing the locking button

Keyway: 0-90°

Surface-hardened and polished punch guide  
for sheet thickness up to 6 mm

Fast and easy clamping system  
for stripper

Suitable for PDC-system

## **Punch body**

Thread M12 with oil channel for sheet lubrication

Punch body made with premium HSS (higher hit  
counts)

## **Stripper**

Interchangeable stripper plate  
with oil channels

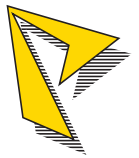

# PASS Beta-V2<sup>®</sup> ABS / Station C

Diameter up to 50,8 mm

	Part-no.	Price in €
<b>Guide Assembly</b>		
for all shapes	4039C01	

<b>Punch body</b>		
Round	4029C01	
Square	4029C02	
Rectangle	4029C03	
Oblong	4029C04	
*O.D. Ground Special Shapes	4029C0G	
* EDM required Special Shapes	4029C0E	

<b>Stripper</b>		
Round	4049C01	
Square	4049C02	
Rectangle	4049C03	
Oblong	4049C04	
*O.D. Ground Special Shapes	4049C0G	
* EDM required Special Shapes	4049C0E	

<b>Die</b>		
Round	4052C01	
Square	4052C02	
Rectangle	4052C03	
Oblong	4052C04	
*O.D. Ground Special Shapes	4052C0G	
* EDM required Special Shapes	4052C0E	

<b>Spare parts:</b>		
PU-ejector Ø 3x6 (in punch)	4092P03	
PU-ejector Ø 6x10 (in punch)	4092P06	

<b>Compensating shims for punch:</b>		
		not necessary

<b>Compensating shims for die:</b>		
1x0,4 mm/1x0,8 mm/1x1,2 mm	499C2M1	24,-- €

<b>Additional costs for punch:</b>	
TICN coating	
T-MAX coating	
WT-shear	
DOWT-shear	
2 PT-shear	
4 PT-shear	
additional keyway	

<b>Additional costs for punch guide:</b>	
additional keyway	

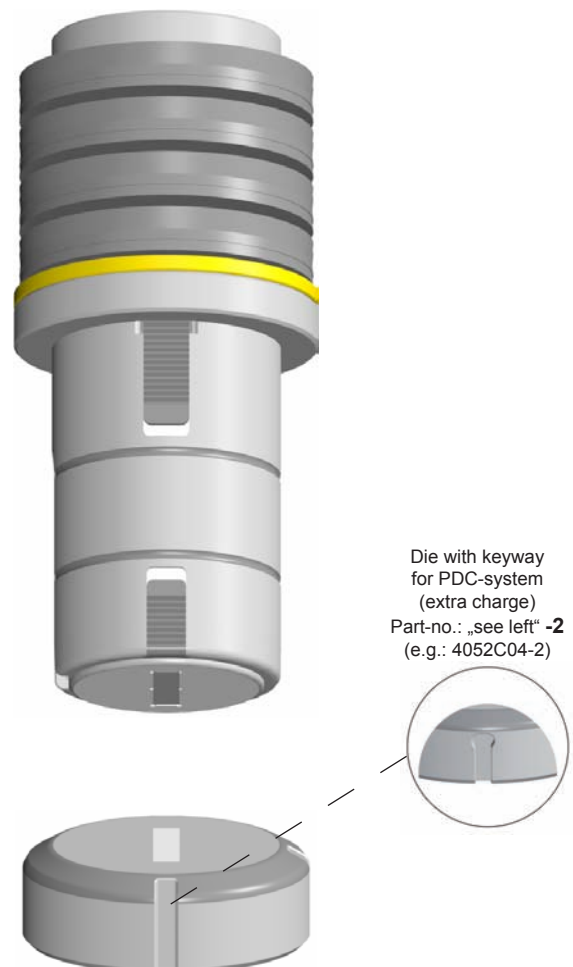

\* see page 28-29



# **PASS Beta-V2<sup>®</sup> ABS / Station C**

## Slitting Tool



### **Guide Assembly**

Screw M12

Springs for sheet thickness up to 6 mm

Oil channel for sheet lubrication

Simple 10 mm length adjustment  
in assembled state by  
pressing the locking button

Keyway: 0-90°

Surface-hardened and polished punch guide  
for sheet thickness up to 6 mm

Fast and easy clamping system  
for stripper

Suitable for PDC-system

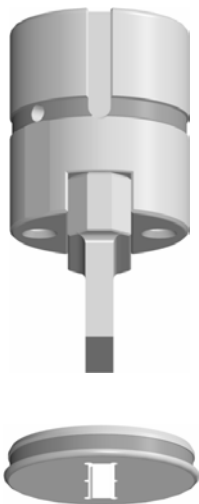

### **Slitting Tool adapter**

2 fixing threads M6

Thread M12 with oil channel for sheet lubrication

### **Slitting Tool**

Punch body made with premium HSS  
(higher hit counts)

### **Stripper**

Interchangeable stripper plate  
with oil channels

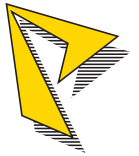

# PASS Beta-V2<sup>®</sup> ABS / Station C

## Slitting Tool

	Part-no.	Price in €
<b>Guide Assembly</b>		

for all shapes	4039C01	
----------------	---------	--

<b>Slitting Tool adapter</b>		
------------------------------	--	--

for all shapes	4229CT00	
----------------	----------	--

<b>Slitting Tool (max. 6,35x50)</b>		
-------------------------------------	--	--

Rectangle	4029CT03	
Oblong	4029CT04	
*Trapezoid G09	4029CT0G	
* Double Trapezoid E03	4029CT0E	

<b>Stripper</b>		
-----------------	--	--

Rectangle	4049CT03	
Oblong	4049CT04	
*Trapezoid G09	4049CT0G	
* Double Trapezoid E03	4049CT0E	

<b>Reversible plate adapter</b>		
---------------------------------	--	--

	4399CT00	
--	----------	--

<b>Reversible plate</b>		
-------------------------	--	--

Rectangle	4052CT03	
Oblong	4052CT04	
*Trapezoid G09	4052CT0G	
* Double Trapezoid E03	4052CT0E	

<b>Spare parts:</b>		
---------------------	--	--

PU-ejector Ø 3x6 (in punch)	4092P03	
PU-ejector Ø 6x10 (in punch)	4092P06	

<b>Compensating shims for Slitting Tool adapter:</b>		
--	--	--

	not necessary	
--	---------------	--

<b>Compensating shims for reversible plate:</b>		
---	--	--

1x0,4 mm/1x0,8 mm/1x1,2 mm	499CT60	
----------------------------	---------	--

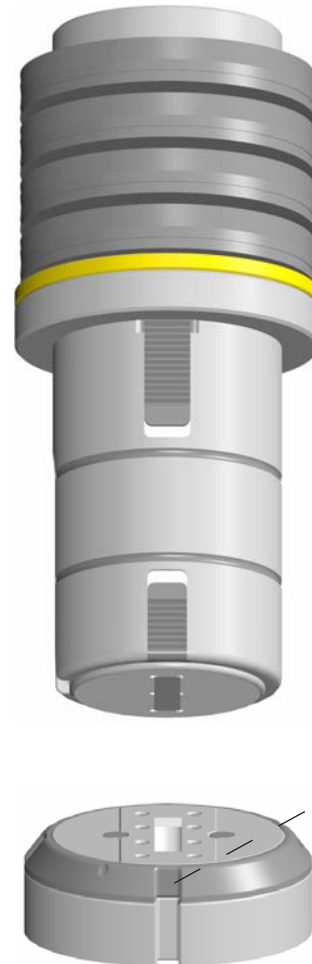

Reversible plate adapter  
with keyway for  
PDC-system  
(extra charge)  
Part-no.: „see left“ -2  
(e.g.: 4399CT00-2)



<b>Additional costs for punch:</b>	
------------------------------------	--

TICN coating	
T-MAX coating	

WT-shear	
DOWT-shear	
2 PT-shear	
4 PT-shear	

additional keyway	
-------------------	--

<b>Additional costs for punch guide:</b>	
--	--

additional keyway	
-------------------	--

\* see page 28-29



# **PASS Beta-V2<sup>®</sup> ABS / Station D**

Diameter up to 88,9 mm



## **Guide Assembly**

Screw M12

Springs for sheet thickness up to 6 mm

Oil channel for sheet lubrication

Simple 10 mm length adjustment  
in assembled state by  
pressing the locking button

Keyway: 0-90°

Surface-hardened and polished punch guide  
for sheet thickness up to 6 mm

Fast and easy clamping system  
for stripper

Suitable for PDC-system

## **Punch body**

Thread M12 with oil channel for sheet lubrication

Punch body made with premium HSS  
(higher hit counts)

## **Stripper**

Interchangeable stripper plate  
with oil channels

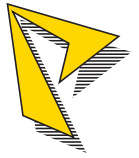

# PASS Beta-V2<sup>®</sup> ABS / Station D

Diameter up to 88,9 mm

	Part-no.	Price in €
<b>Guide Assembly</b>		
for all shapes	4039D01	

<b>Punch body</b>		
Round	4029D01	
Square	4029D02	
Rectangle	4029D03	
Oblong	4029D04	
*O.D. Ground Special Shapes	4029D0G	
* EDM required Special Shapes	4029D0E	

<b>Stripper</b>		
Round	4049D01	
Square	4049D02	
Rectangle	4049D03	
Oblong	4049D04	
*O.D. Ground Special Shapes	4049D0G	
* EDM required Special Shapes	4049D0E	

<b>Die</b>		
Round	4052D01	
Square	4052D02	
Rectangle	4052D03	
Oblong	4052D04	
*O.D. Ground Special Shapes	4052D0G	
* EDM required Special Shapes	4052D0E	

<b>Spare parts:</b>		
PU-ejector Ø 3x6 (in punch)	4092P03	
PU-ejector Ø 6x10 (in punch)	4092P06	

<b>Compensating shims for punch:</b>		
		not necessary

<b>Compensating shims for die:</b>		
1x0,4 mm/1x0,8 mm/1x1,2 mm	499D2M1	



Die with keyway for PDC-system (extra charge)  
Part-no.: „see left“ -2  
(e.g.: 4052D04-2)

**Additional costs for punch:**

TICN coating  
T-MAX coating

WT-shear  
DOWT-shear  
2 PT-shear  
4 PT-shear

additional keyway

**Additional costs for punch guide:**

additional keyway

\* see page 28-29

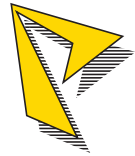

# **PASS Beta-V2<sup>®</sup> ABS/ Station D**

## Slitting Tool



### **Guide Assembly**

Screw M12

Springs for sheet thickness up to 6 mm

Oil channel for sheet lubrication

Simple 10 mm length adjustment  
in assembled state by  
pressing the locking button

Keyway: 0-90°

Surface-hardened and polished punch guide  
for sheet thickness up to 6 mm

Fast and easy clamping system  
for stripper

Suitable for PDC-system

### **Slitting Tool adapter**

2 fixing threads M6

Thread M12 with oil channel for sheet lubrication

### **Slitting Tool**

Punch body made with premium HSS  
(higher hit counts)

### **Stripper**

Interchangeable stripper plate  
with oil channels

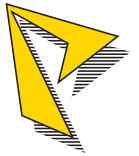

# PASS Beta-V2<sup>®</sup> ABS / Station D

## Slitting Tool

	Part-no.	Price in €
<b>Guide Assembly</b>		

for all shapes	4039D01	
----------------	---------	--

<b>Slitting Tool adapter</b>		
------------------------------	--	--

for all shapes	4229DT00	
----------------	----------	--

<b>Slitting Tool (max. 6,35x85)</b>		
-------------------------------------	--	--

Rectangle	4029DT03	
Oblong	4029DT04	
*Trapezoid G09	4029DT0G	
* Double Trapezoid E03	4029DT0E	

<b>Stripper</b>		
-----------------	--	--

Rectangle	4049DT03	
Oblong	4049DT04	
*Trapezoid G09	4049DT0G	
* Double Trapezoid E03	4049DT0E	

<b>Reversible plate adapter</b>		
---------------------------------	--	--

	4399DT00	
--	----------	--

<b>Reversible plate</b>		
-------------------------	--	--

Rectangle	4052DT03	
Oblong	4052DT04	
*Trapezoid G09	4052DT0G	
* Double Trapezoid E03	4052DT0E	

<b>Spare parts:</b>		
---------------------	--	--

PU-ejector Ø 3x6 (in punch)	4092P03	
PU-ejector Ø 6x10 (in punch)	4092P06	

<b>Compensating shims for Slitting Tool adapter:</b>		
--	--	--

	not necessary	
--	---------------	--

<b>Compensating shims for reversible plate:</b>		
---	--	--

1x0,4 mm/1x0,8 mm/1x1,2 mm	499DT60	
----------------------------	---------	--

<b>Additional costs for punch:</b>	
------------------------------------	--

TICN coating	
T-MAX coating	

WT-shear	
DOWT-shear	
2 PT-shear	
4 PT-shear	

additional keyway	
-------------------	--

<b>Additional costs for punch guide:</b>	
--	--

additional keyway	
-------------------	--



Reversible plate adapter  
with keyway for  
PDC-system  
(extra charge)  
Part-no.: „see left“ -2  
(e.g.: 4399DT00-2)



\* see page 28-29



# **PASS Beta-V2<sup>®</sup> ABS / Station D**

## Slitting Tool close to clamp

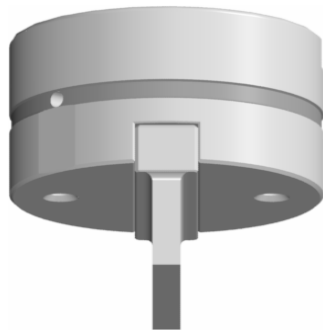

### **Guide Assembly**

Screw M12

Springs for sheet thickness up to 6 mm

Oil channel for sheet lubrication

Simple 10 mm length adjustment  
in assembled state by  
pressing the locking button

Keyway: 0-90°

Surface-hardened and polished punch guide  
for sheet thickness up to 6 mm

Fast and easy clamping system  
for stripper

Suitable for PDC-system

### **Slitting Tool adapter**

2 fixing threads M6

Thread M12 with oil channel for sheet lubrication

### **Slitting Tool**

Punch body made with premium HSS  
(higher hit counts)

### **Stripper**

Interchangeable stripper plate  
with oil channels

One or two-sided relief  
for punching close to clamp

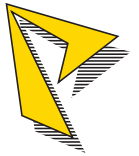

# PASS Beta-V2<sup>®</sup> ABS / Station D

## Slitting Tool close to clamp

Part-no. Price in €

### Guide Assembly

for all shapes 4039DTP01

### Slitting Tool adapter

for all shapes 4229DT00

### Slitting Tool (max. 6,35x85)

Rectangle	4029DT03
Oblong	4029DT04
*Trapezoid G09	4029DT0G
* Double Trapezoid E03	4029DT0E

### Stripper one-sided free

Rectangle	4049DTP03-1
Oblong	4049DTP04-1
*Trapezoid G09	4049DTP0G-1
* Double Trapezoid E03	4049DTP0E-1

### Stripper two-sided free

Rectangle	4049DTP03-2
Oblong	4049DTP04-2
*Trapezoid G09	4049DTP0G-2
* Double Trapezoid E03	4049DTP0E-2

### Die one-sided free

Rectangle	4052DTP03-1
Oblong	4052DTP04-1
*Trapezoid G09	4052DTP0G-1
* Double Trapezoid E03	4052DTP0E-1

### Die two-sided free

Rectangle	4052DTP03-2
Oblong	4052DTP04-2
*Trapezoid G09	4052DTP0G-2
* Double Trapezoid E03	4052DTP0E-2

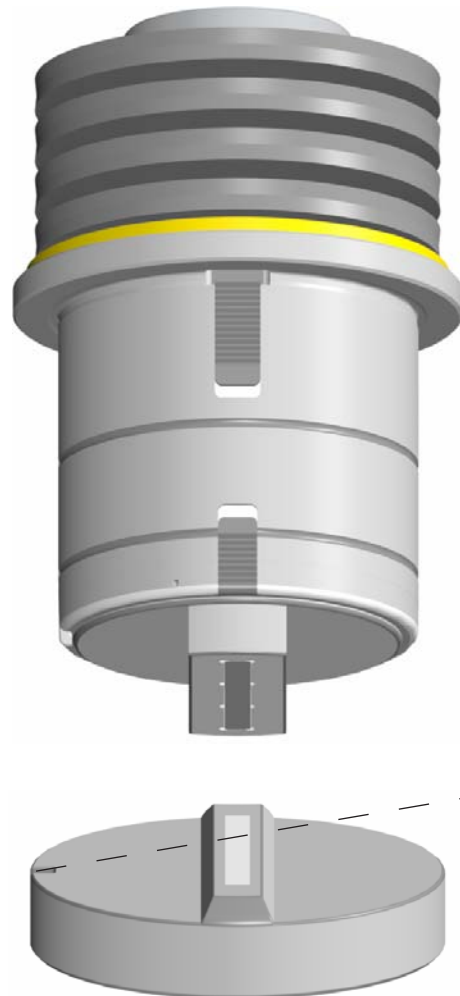

Die with keyway for PDC-system (extra charge)  
Part-no.: „see left“ -2  
(e.g.: 4052DTP04-1-2)



### Spare parts:

PU-ejector Ø 3x6 (in punch)	4092P03
PU-ejector Ø 6x10 (in punch)	4092P06

### Additional costs for punch:

TICN coating  
T-MAX coating

WT-shear  
DOWT-shear  
2 PT-shear  
4 PT-shear

additional keyway

### Compensating shims for Slitting Tool adapter:

not necessary

### Compensating shims for die:

1x0,4 mm/1x0,8 mm/1x1,2 mm	499D2M1
----------------------------	---------

### Additional costs for punch guide:

additional keyway

\* see page 28-29



# **PASS Beta-V2<sup>®</sup> ABS/ Station E**

Diameter up to 114,3 mm



## **Guide Assembly**

Screw M12

Springs for sheet thickness up to 6 mm

Oil channel for sheet lubrication

Simple 10 mm length adjustment  
in assembled state by  
pressing the locking button

Keyway: 0-90°

Surface-hardened and polished punch guide  
for sheet thickness up to 6 mm

Fast and easy clamping system  
for stripper

Suitable for PDC-system

## **Punch body**

Thread M12 with oil channel for sheet lubrication

Punch body made with premium HSS  
(higher hit counts)

## **Stripper**

Interchangeable stripper plate  
with oil channels

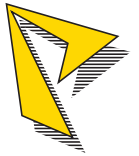

# PASS Beta-V2<sup>®</sup> ABS / Station E

Diameter up to 114,3 mm

	Part-no.	Price in €
<b>Guide Assembly</b>		

for all shapes	4039E01	
----------------	---------	--

<b>Punch body</b>		
Round	4029E01	
Square	4029E02	
Rectangle	4029E03	
Oblong	4029E04	
*O.D. Ground Special Shapes	4029E0G	
* EDM required Special Shapes	4029E0E	

<b>Stripper</b>		
Round	4049E01	
Square	4049E02	
Rectangle	4049E03	
Oblong	4049E04	
*O.D. Ground Special Shapes	4049E0G	
* EDM required Special Shapes	4049E0E	

<b>Die</b>		
Round	4052E01	
Square	4052E02	
Rectangle	4052E03	
Oblong	4052E04	
*O.D. Ground Special Shapes	4052E0G	
* EDM required Special Shapes	4052E0E	

<b>Spare parts:</b>		
PU-ejector Ø 3x6 (in punch)	4092P03	
PU-ejector Ø 6x10 (in punch)	4092P06	

<b>Compensating shims for punch:</b>		
		not necessary

<b>Compensating shims for die:</b>		
1x0,4 mm/1x0,8 mm/1x1,2 mm	499E2M1	

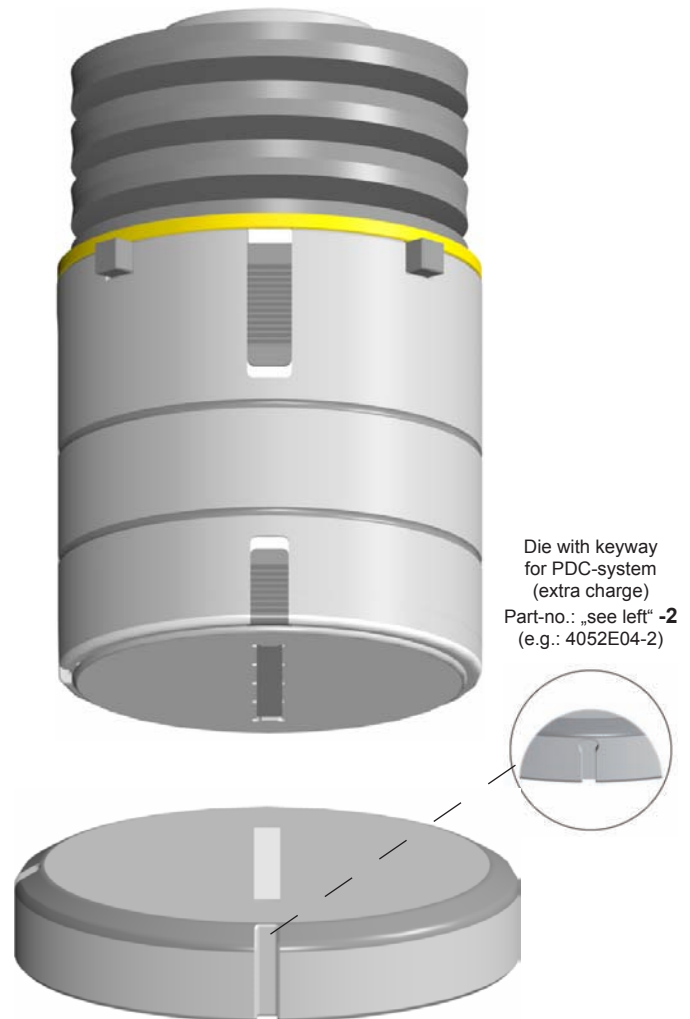

Die with keyway for PDC-system (extra charge)  
Part-no.: „see left“ -2  
(e.g.: 4052E04-2)

<b>Additional costs for punch:</b>	
TICN coating	
T-MAX coating	
WT-shear	
DOWT-shear	
2 PT-shear	
4 PT-shear	
additional keyway	

<b>Additional costs for punch guide:</b>	
additional keyway	

\* see page 28-29



# **PASS Beta-V2<sup>®</sup> ABS / Station E**

## Slitting Tool

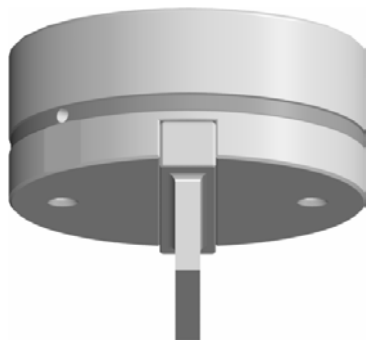
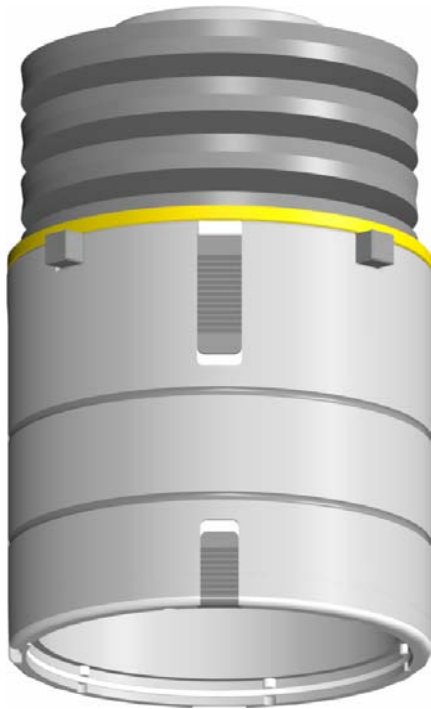

### **Guide Assembly**

Screw M12

Springs for sheet thickness up to 6 mm

Oil channel for sheet lubrication

Simple 10 mm length adjustment  
in assembled state by  
pressing the locking button

Keyway: 0-90°

Surface-hardened and polished punch guide  
for sheet thickness up to 6 mm

Fast and easy clamping system  
for stripper

Suitable for PDC-system

### **Slitting Tool adapter**

2 fixing threads M6

Thread M12 with oil channel for sheet lubrication

### **Slitting Tool**

Punch body made with premium HSS  
(higher hit counts)

### **Stripper**

Interchangeable stripper plate  
with oil channels

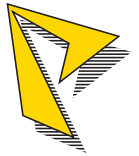

# PASS Beta-V2<sup>®</sup> ABS / Station E Slitting Tool

**Part-no. Price in €**

**Guide Assembly**

for all shapes 4039E01

**Slitting Tool adapter**

for all shapes 4229ET00

**Slitting Tool (max. 6,35x111)**

Rectangle 4029ET03  
Oblong 4029ET04  
\*Trapezoid G09 4029ET0G  
\* Double Trapezoid E03 4029ET0E

**Stripper**

Rectangle 4049ET03  
Oblong 4049ET04  
\*Trapezoid G09 4049ET0G  
\* Double Trapezoid E03 4049ET0E

**Reversible plate adapter**

4399ET00

**Reversible plate**

Rectangle 4052ET03  
Oblong 4052ET04  
\*Trapezoid G09 4052ET0G  
\* Double Trapezoid E03 4052ET0E

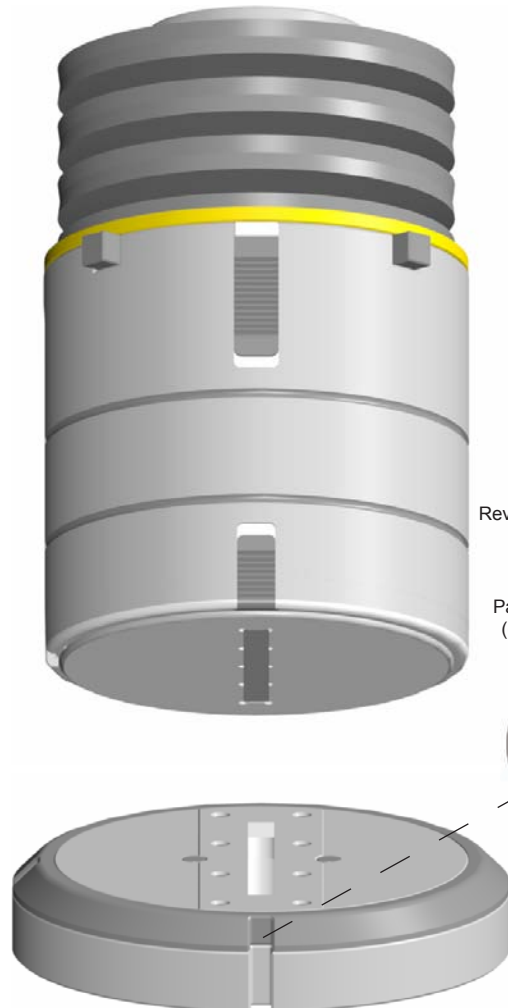

Reversible plate adapter  
with keyway for  
PDC-system  
(extra charge)  
Part-no.: „see left“ -2  
(e.g.: 4399ET00-2)



**Spare parts:**

PU-ejector Ø 3x6 (in punch) 4092P03  
PU-ejector Ø 6x10 (in punch) 4092P06

**Additional costs for punch:**

TICN coating  
T-MAX coating

WT-shear  
DOWT-shear  
2 PT-shear  
4 PT-shear

additional keyway

**Compensating shims for Slitting Tool adapter:**

not necessary

**Compensating shims for reversible plate:**

1x0,4 mm/1x0,8 mm/1x1,2 mm 499ET60

**Additional costs for punch guide:**

additional keyway

\* see page 28-29



# **PASS Beta-V2<sup>®</sup> ABS / Station E**

## Slitting Tool close to clamp

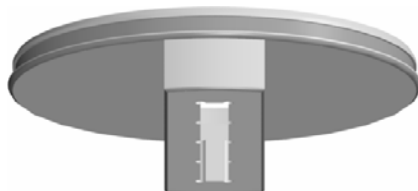
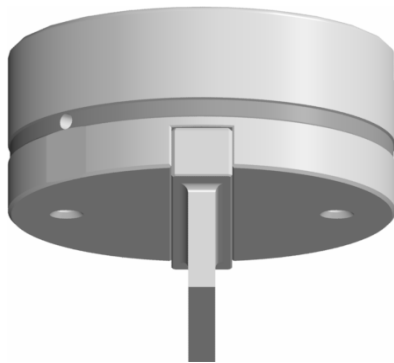

### **Guide Assembly**

Screw M12

Springs for sheet thickness up to 6 mm

Oil channel for sheet lubrication

Simple 10 mm length adjustment  
in assembled state by  
pressing the locking button

Keyway: 0-90°

Surface-hardened and polished punch guide  
for sheet thickness up to 6 mm

Fast and easy clamping system  
for stripper

Suitable for PDC-system

### **Slitting Tool adapter**

2 fixing thread M6

Thread M12 with oil channel for sheet lubrication

### **Slitting Tool**

Punch body made with premium HSS  
(higher hit counts)

### **Stripper**

Interchangeable stripper plate

One or two-sided relief  
for punching close to clamp

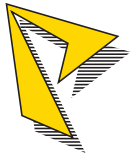

# PASS Beta-V2<sup>®</sup> ABS / Station E

## Slitting Tool close to clamp

Part-no. Price in €

### Guide Assembly

for all shapes 4039ETP01

### Slitting Tool adapter

for all shapes 4229ET00

### Slitting Tool (max. 6,35x111)

Rectangle	4029ET03
Oblong	4029ET04
*Trapezoid G09	4029ET0G
* Double Trapezoid E03	4029ET0E

### Stripper one-sided free

Rectangle	4049ETP03-1
Oblong	4049ETP04-1
*Trapezoid G09	4049ETP0G-1
* Double Trapezoid E03	4049ETP0E-1

### Stripper two-sided free

Rectangle	4049ETP03-2
Oblong	4049ETP04-2
*Trapezoid G09	4049ETP0G-2
* Double Trapezoid E03	4049ETP0E-2

### Die one-sided free

Rectangle	4052ETP03-1
Oblong	4052ETP04-1
*Trapezoid G09	4052ETP0G-1
* Double Trapezoid E03	4052ETP0E-1

### Die two-sided free

Rectangle	4052ETP03-2
Oblong	4052ETP04-2
*Trapezoid G09	4052ETP0G-2
* Double Trapezoid E03	4052ETP0E-2

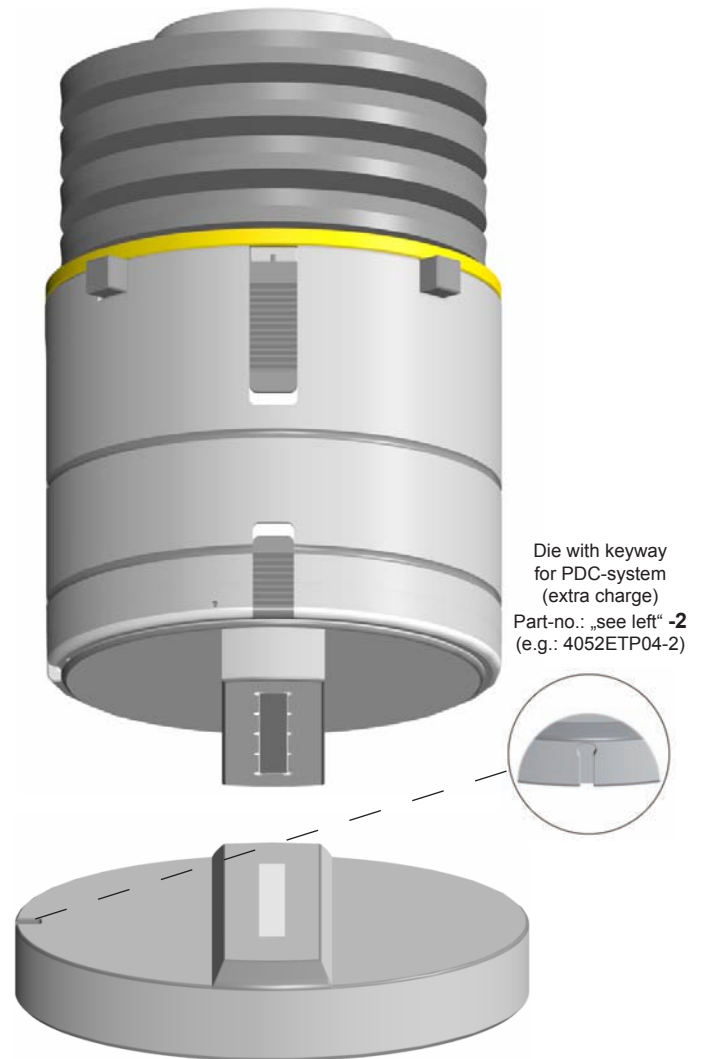

### Spare parts:

PU-ejector Ø 3x6 (in punch)	4092P03
PU-ejector Ø 6x10 (in punch)	4092P06

### Additional costs for punch:

TICN coating  
T-MAX coating

WT-shear  
DOWT-shear  
2 PT-shear  
4 PT-shear

additional keyway

### Compensating shims for Slitting Tool adapter:

not necessary

### Compensating shims for die:

1x0,4 mm/1x0,8 mm/1x1,2 mm	499E2M1
----------------------------	---------

### Additional costs for punch guide:

additional keyway

\* see page 28-29

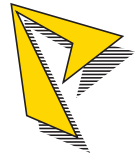

# O.D. Ground Special shapes

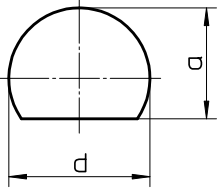
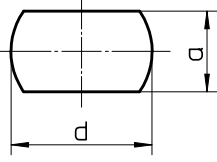
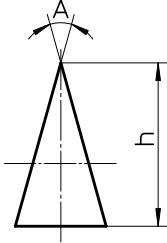
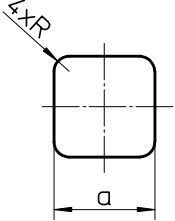
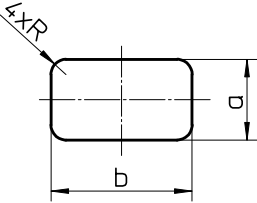
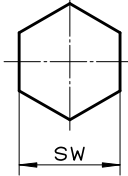
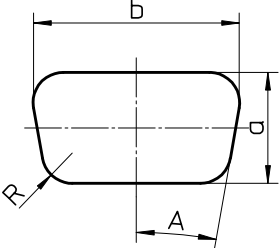
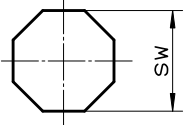
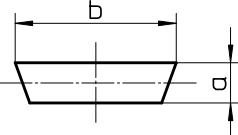
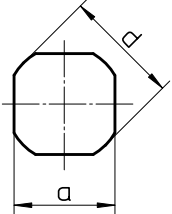
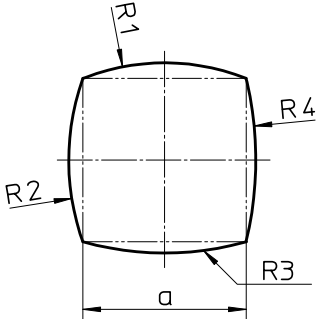
 <p>G01</p>	 <p>G02</p>	 <p>G03</p>
 <p>G04</p>	 <p>G05</p>	 <p>G06</p>
 <p>G07</p>	 <p>G08</p>	 <p>G09</p>
 <p>G10</p>	 <p>G11</p>	<p><i>Please inquire for other shapes not indicated in this page!</i></p>

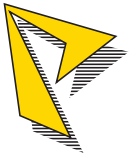

# EDM required Special shapes

<p>E01</p>	<p>E02</p>	<p>E03</p>
<p>E04</p>	<p>E05</p>	<p>E06</p>
<p>E07</p>	<p>E08</p>	<p>E09</p>
<p>E10</p>	<p>E11</p>	<p><i>Please inquire for other shapes not indicated in this page!</i></p>